

THE LINDE GROUP

Linde

Hydrogen



Introduction.

Linde - the company's background in the hydrogen business.

Ever since hydrogen was in demand in the chemical and fertilizer industry – and more recently in the petrochemicals field – Linde was involved with the latest improvements in hydrogen generation. For example, the purification of various industrial raw gas feedstocks like coke oven and coal gasification gases, sophisticated and tailor made sourgas steps with chemical and/or physical absorption, and adsorption steps followed by low temperature purification and rectification processes with “cold box” units.

Hydrogen.

The demand of hydrogen grew as the world's consumption of refinery products increased by the ever growing industrialization.

The demand for better and more abundant automotive fuels called for better yields from the limited feedstock crude oil. In turn the demand for hydrogen import grew to balance the hydrogen refining catalytic refinery process steps.

Amongst all hydrogen technology suppliers, Linde is the outstanding contractor for complete hydrogen plants and the only company who owns all technologies inhouse, covering the complete range of petrochemical feedstocks from natural gas through LPG, refinery off-gases and naphtha up to heavy fuel oil, asphalt and coal.

These technologies are basically:

- Steam reforming technology for light HC-feedstock combined with Linde's own PSA systems for hydrogen purification.
- Partial oxidation technology for heavy HC-feedstock followed by a sequence of various integrated process steps to shift, desulfurize and purify the raw hydrogen. The pure oxygen for the gasification is produced with a Linde air separation unit.

Hydrogen plant in Germany





Hydrogen plant in Australia

The specific Linde know-how in all these fields are the essential advantage for a successful integration and complete inhouse optimization of all process sections. The results are highly efficient and reliably operating hydrogen plants.

Since the early 70's Linde favoured and promoted with innovative improvements the now well established steam reforming/pressure swing adsorption technology for the production of pure and ultrapure hydrogen preferably from light hydrocarbon feedstock.

Proven know-how in design and construction of furnaces, steam reformers and heaters has been completed with the acquisition of Selas of America, which is now Selas Fluid Processing Co. in the USA and SELAS-LINDE GmbH in Germany. Linde together with Selas have developed their own proprietary top fired reformer design.

Combining the know-how of the Engineering Division – and the Gases Division – the company is in the unique position to build, own and operate complete hydrogen plants for continuous supply of hydrogen over the fence to large refineries and chemical companies. The extensive feedback of operating data and information on process and equipment performance in operating plants provides Linde with substantial background for the yet more efficient design of future plants.

More than 200 new hydrogen plants have been built all over the world, for clients in the refining, chemical and fertilizer industry, with capacities ranging from below 1,000 Nm³/h to well above 100,000 Nm³/h, and for processing of all types of feedstock. Most of these plants have been built on a lump-sum turn-key basis.

Production of hydrogen from light hydrocarbons.

Linde has a well-proven technology for hydrogen manufacture by catalytic steam reforming of light hydrocarbons in combination with Linde's highly efficient pressure swing adsorption process.

A typical flowsheet for a Linde designed large capacity hydrogen plant is shown in figure 1.

The basic process steps

1. Hydrodesulfurization of feed stock
2. Steam reforming
3. Heat recovery from reformed and from combustion flue gas to produce process and export steam
4. Single stage adiabatic high temperature CO-shift conversion
5. Final hydrogen purification by pressure swing adsorption

Figure 1

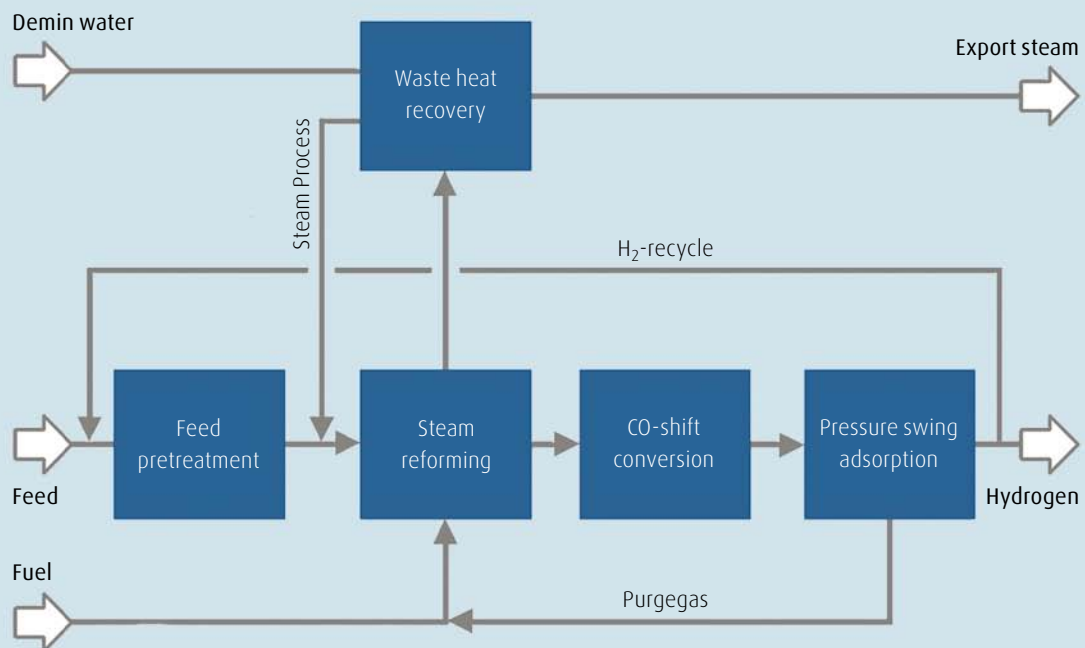



Process features.

Process design and optimization for every process step and in particular the optimized linking of operating parameters between the two essential process steps: reforming furnace and pressure swing adsorption unit are based exclusively on Linde's own process and operating know-how.

Commissioning and start-up of the plants as well as operator training and after sales service are performed by experienced specialists.

The reformer furnace

A compact fire box design with vertical hanging catalyst tubes arranged in multiple, parallel rows. Minimized number of forced draft top-firing burners, integrated into the firebox ceiling. Compared to other designs, burner trimming and individual adjustment to achieve a uniform heat flow pattern throughout the reformer cross section is substantially facilitated.

Concurrent firing ensures a uniform temperature profile throughout the reformer tube length. Flame and stable combustion flow pattern is

supported by the flue gas collecting channels arranged at ground level between the hot reformed gas headers. Thermal expansion as well as tube and catalyst weight are compensated by the adjustable spring hanger system arranged inside the penthouse, removing the mechanical stress from the hot manifold outlet headers at ground level.

The radiant reformer box is insulated with multiple layers of ceramic fibre blanket insulation, mechanically stable and resistant to thermal stress.

Convection section

Depending on the hydrogen product capacity, the convection section - a series of serial heat exchanger coils - is arranged either vertically with ID-fluegas fan and stack at reformer burner level or - specifically for the higher capacity units - horizontally at ground level for ease of access and reduced structural requirements.

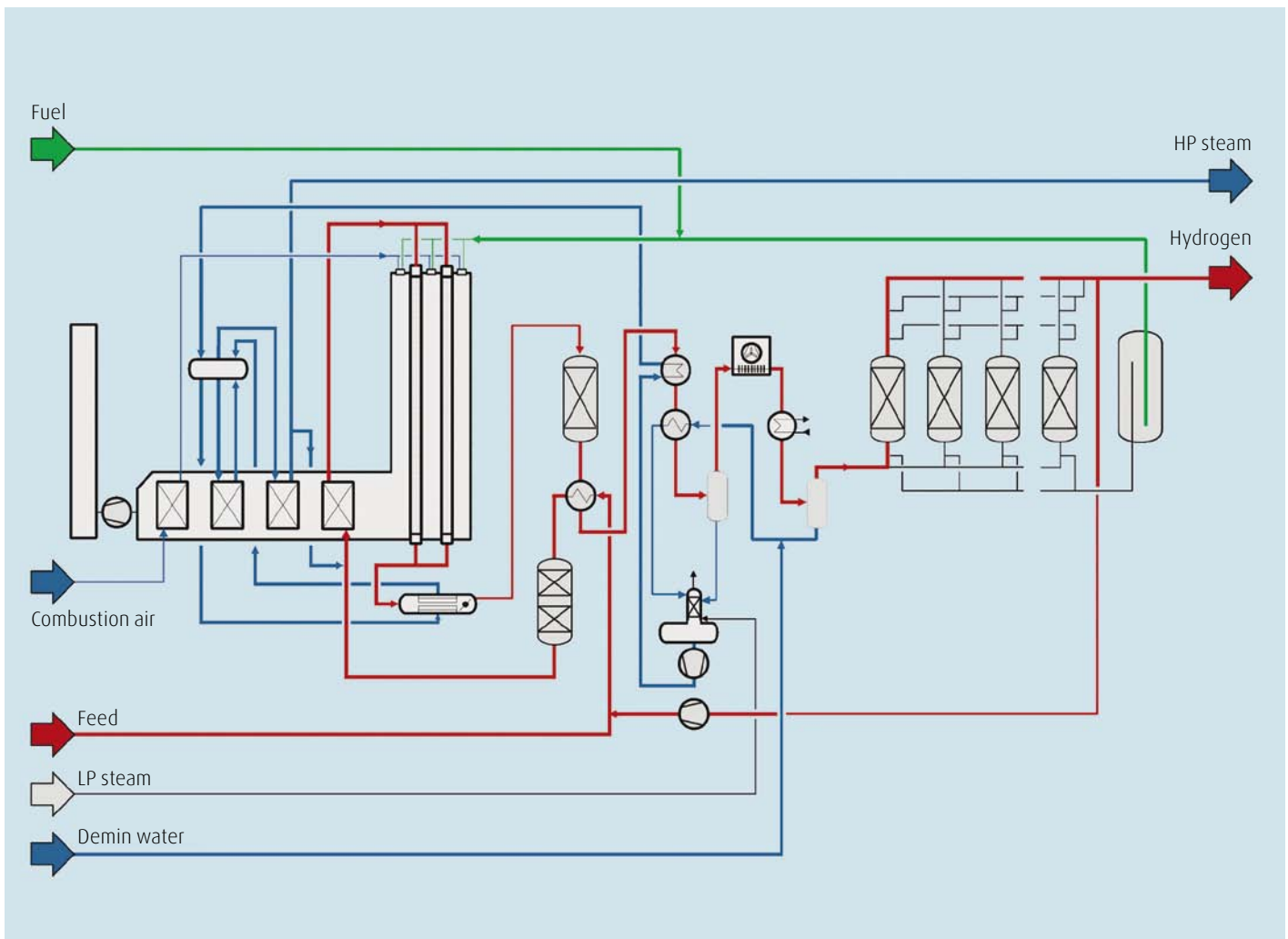



Pressure swing adsorption

The particular features of Linde's PSA technology are high product recovery rates, low operating costs and operational simplicity. Excellent availability and easy monitoring are ensured by advanced computer control. Extensive know-how and engineering expertise assisted by highly sophisticated computer programs guarantee the design and construction of tailor-made and economical plants of the highest quality. Modular skid design of the PSA plants reduces erection time and costs at site. The fully prefabricated skids are thoroughly tested before they leave the workshop.

Smooth operation to protect catalysts and reforming tubes require a thorough feed back from the internal PSA computer system regarding purgegas flow and heating value. This enables the control system to control the furnace's total fuel management in dependence on the final hydrogen product flow.

Safety philosophy

Safety (Hazop-) studies and ESD-system design philosophy are based not only on more than 30 years of steam reforming plant experience but on the cumulative know-how, which the Linde safety experts gained with numerous turn-key lump-sum contracts, especially for large-scale synthesis gas plants as well as for complex olefin production units.

Environmental protection

For steam reforming based hydrogen plants, special care is taken regarding gaseous emission of NO_x and CO, calculation of outdoor sound propagation and measurement of noise emission design, design of blow-down and flare system, considering permissible levels for heat radiation and air pollution etc.

[Hydrogen plant in China](#)

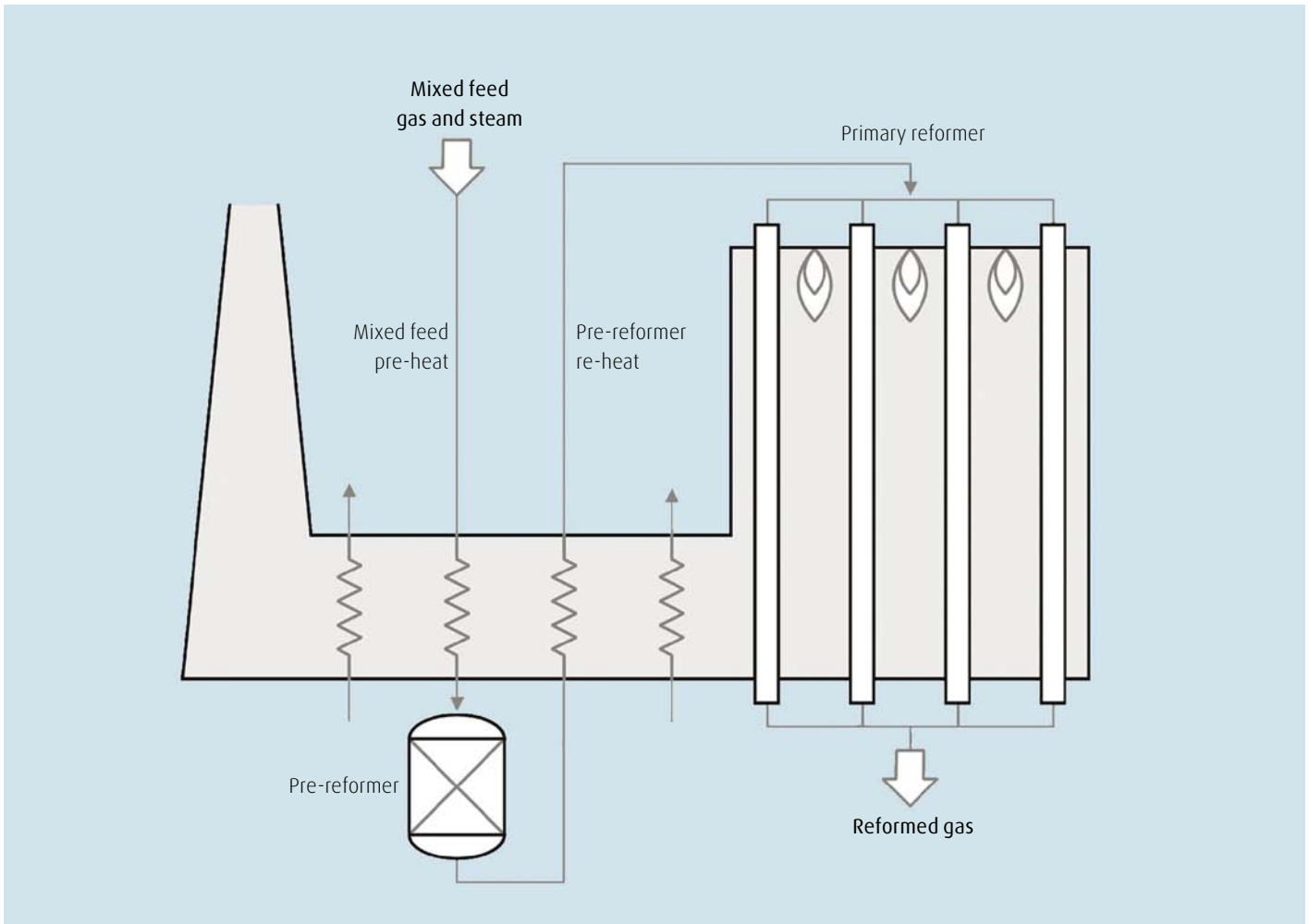

Process options.

Pre-reforming

Pre-reforming is the term applied to the low temperature steam reforming of hydrocarbons in a simple adiabatic reactor using highly active, nickel based catalyst, which promotes the steam reforming reaction at low temperatures. This process was developed in the 1960's for town gas and synthetic natural gas (SNG) production.

Feedstock - ranging from natural gas to naphtha is converted by the steam reforming reaction to give an equilibrium mixture containing hydrogen, carbon oxides, methane and steam. Depending on the feedstock, the temperature profile can be either endothermic or exothermic.

The advantages provided through the inclusion of a pre-reforming unit may often be plant specific. Some or all of the following advantages may apply to a specific case

- Fuel savings over stand alone primary reformer
- Reduced capital cost of reformer
- Higher primary reformer preheat temperatures
- Increased feedstock flexibility
- Lower involuntary steam production
- Lower overall steam/carbon ratios
- Provides protection for the main reformer

In its most common application today the main benefit comes from the ability to effectively transfer reforming heat load from the radiant section of a reformer to its convection section.

MT-shift

Apart from the conventional adiabatic MT-shift, Linde developed and successfully installed the isothermal Medium Temperature shift reactor, a fixed bed reactor suitable for exothermic and endothermic catalyst reactions, with an integrated helically coiled tube heat exchanger for cooling or heating of the catalyst.

In the case of isothermal MTS the exothermic catalytic reaction heat is removed by producing steam, with only a few degrees of temperature difference throughout the reactor. This isothermal reactor type is successfully applied in the chemical industry for the methanol synthesis, for methanation, hydrogenation and for the Linde CLINSULF[®] sulfur recovery.

Gas heated reforming (GHR)

The GHR unit is a combination of a gas heated reformer and an oxygen-fired autothermal reformer, where the heat of reaction is supplied by the hot gas exiting the autothermal reformer.

The main advantages of the GHR process:

- Lower energy consumption
- Lower investment costs
- Primary reformer with flue gas waste heat recovery system is eliminated
- No steam production in the reformed gas cooling section, thus eliminating the waste heat boiler
- As steam/power generation and oxygen production are confined to independent units, opportunities exist for "over the fence supply"
- Optimum consideration of environmental aspects with regard to zero flue gas from the core unit and relevant minimum charges originating from the potential power/steam generation unit

The convective as well as the autothermal step can be individually integrated in flow schemes for revamping and capacity increase of existing conventional hydrogen plants.



Isothermal reactor

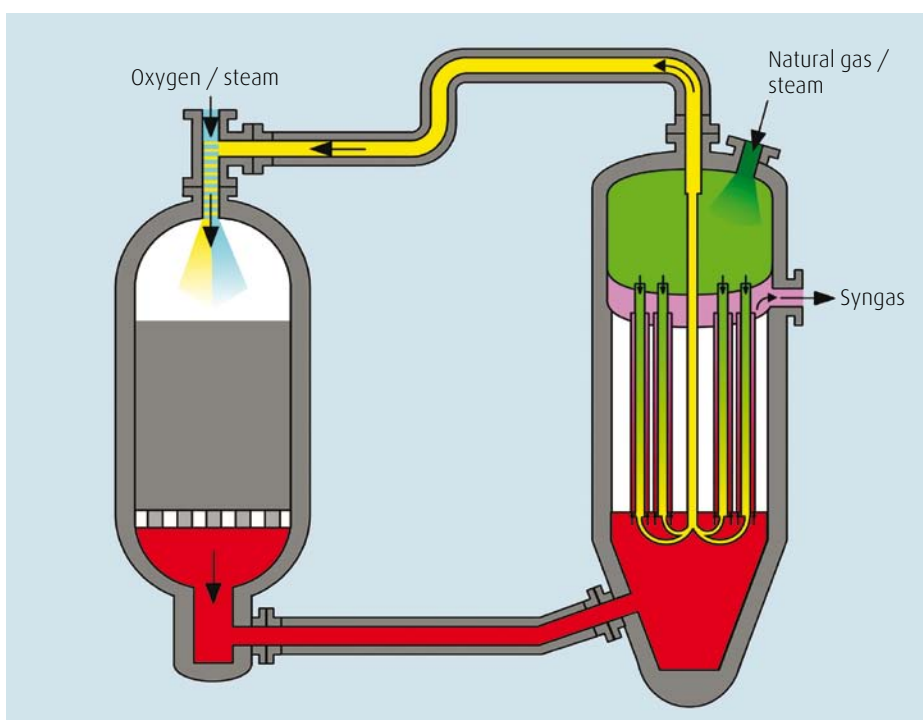

Gas heated reforming



Reformer furnace

Typical Performance Figures of a Steam Reforming based Hydrogen Plant

			Natural gas	LPG	Naphtha	Refinery gas
Product hydrogen	flow rate	Nm ³ /h	50,000	50,000	50,000	50,000
		MMSCFD	44.8	44.8	44.8	44.8
	pressure	bara	25.0	25.0	25.0	25.0
	purity	mol-%	99.9	99.9	99.9	99.9
Export steam	flow rate	T/hr	31	28.9	28.6	29.2
	temperature	°C	390	390	390	390
	pressure	bara	40	40	40	40
Feed and fuel consumption		Gcal/hr	177.8	181.8	182.9	175.8
		GJ/hr	744.4	761.2	765.8	736.0
Energy consumption (incl. steam credit)		Gcal/1,000 Nm ³ H ₂	3.070	3.210	3.222	3.072
		GJ/1,000 Nm ³ H ₂	12.853	13.440	13.490	12.862
Utilities	demin. water	T/hr	55.6	57.5	60.6	53.2
	cooling water	T/hr	160	165	168	157
	electrical energy	kW	850	920	945	780
Design flexibility	export steam production	T/1,000 Nm ³ H ₂	0.5 - 1.2	0.4 - 1.2	0.4 - 1.2	0.4 - 1.1
	fuel consumption	GJ/1,000 Nm ³ H ₂	0.9 - 3.5	1.8 - 4.3	1.9 - 4.4	0.7 - 2.9

Modular hydrogen plants.

With its subsidiary Hydro-Chem Linde has a leading position in prefabricated and skid-mounted steam reforming hydrogen plants including methanol cracking.

Markets served

Modular hydrogen plants with typical capacities from 150 to 12,000 Nm³/h are designed with the following industries in mind:

- Food industry
- Steel industry
- Glass industry
- Polysilicon (electronics and solar panel)
- Hydrogen peroxide production
- Hydrogenation processes/oil refineries
- Oleochemicals

Technology

These modular hydrogen plants are based on inhouse steam reforming technology employing a round up-fired can reformer type design. Followed by a purification step using in-house-standard 4 or 5-bed PSA technology.

Design

The modular plant is designed to meet exact customer needs. The pre-assembled modular designs satisfy the most demanding product requirements. The layout is optimized to minimize space and to ease maintenance.

Automation

The modular designed hydrogen plant can be supplied with fully automatic remote control for unmanned operation including safe start-up and shut-down, supervised by common service centers.

Modular Fabrication

Modular fabrication of hydrogen facilities is done in own and/or selected external workshops, where for example heat exchangers, vessels, boilers and piping assemblies are fabricated. All of the components are assembled in the workshops into compact, low-cost and easy to install modular units. The pre-assembled units offer the most economical layout without sacrificing access for operation and maintenance.

Modular hydrogen plant





Liquid hydrogen production facility at refinery
in Leuna, Germany

Liquid hydrogen technology.

Liquid hydrogen technology

Hydrogen is the vehicle fuel for the future - a safe and pollution free, environmentally friendly alternative to gasoline and kerosene. Linde is fully prepared to meet this challenge and is already cooperating with companies such as BMW, Daimler, GM and Shell on the development of fueling and storage technologies. Today of course there are already many applications for liquid hydrogen, e.g. in rocket propulsion and semi-conductor manufacture, where high purity blanketing gas is required.

Typical industrial plants supplied by Linde for these applications are:

- The BOC
- AIRCO facility in MAGOG
- Canada with a capacity of 13,600 kg/d.

Additionally plants with smaller capacities, down to 500 kg/d, have been supplied to various countries. Again Linde's involvement in hydrogen technology covers not only liquefaction but also purification, distribution and storage as well as all aspects of safe handling. A reference for this are the cryogenic propellant storage and handling system for the ARIANE 5 rocket propulsion test facilities SEP, France and DLR, Germany. To promote the development of the necessary hydrogen infrastructure for vehicles, Linde is engaged in feasibility studies with AIRBUS Industries and the European Quebec Hydrogen Project (EQHPPP).



LH₂- fueling station in USA



Mobile CGH₂ and LH₂- fueling station



Δ CGH₂- fueling station in Tokio

CGH₂ and LH₂- fueling station in Germany ▽



Designing processes – constructing plants.

Linde's Engineering Division continuously develops extensive process engineering know-how in the planning, project management and construction of turnkey industrial plants.

The range of products comprises:

- Petrochemical plants
- LNG and natural gas processing plants
- Synthesis gas plants
- Hydrogen plants
- Gas processing plants
- Adsorption plants
- Air separation plants
- Cryogenic plants
- Biotechnological plants
- Furnaces for petrochemical plants and refineries

Linde and its subsidiaries manufacture:

- Packaged units, cold boxes
- Coil-wound heat exchangers
- Plate-fin heat exchangers
- Cryogenic standard tanks
- Air heated vaporizers
- Spiral-welded aluminium pipes

More than 3,800 plants worldwide document the leading position of the Engineering Division in international plant construction.

Engineering Division

Schalchen Plant
Tacherting, Germany
Phone +49.8621.85-0
Fax +49.8621.85-6620
plantcomponents@linde-le.com

Linde-KCA-Dresden GmbH

Dresden, Germany
Phone +49.351.250-30
Fax +49.351.250-4800
lkca.dresden@linde-kca.com

Selas-Linde GmbH

Pullach, Germany
Phone +49.89.7447-470
Fax +49.89.7447-4717
selas-linde@linde-le.com

Cryostar SAS

Hésingue, France
Phone +33.389.70-2727
Fax +33.389.70-2777
info@cryostar.com

Linde CryoPlants Ltd.

Aldershot, Great Britain
Phone +44.1.252.3313-15
Fax +44.1.252.3430-62
info@linde-lcl.com

Linde Impianti Italia S.p.A.

Rome, Italy
Phone +39.066.5613-1
Fax +39.066.5613-200
r.tikovsky@lindeimpianti.it

Linde Kryotechnik AG

Pfungen, Switzerland
Phone +41.52.3040-555
Fax +41.52.3040-550
info@linde-kryotechnik.ch

Cryo AB

Göteborg, Sweden
Phone +46.3164-6800
Fax +46.3164-2220
gunnar.lenneras@cryo.aga.com

Linde Process Plants, Inc.

Tulsa, OK, U.S.A.
Phone +1.918.4771-200
Fax +1.918.4771-100
sales@lppusa.com

Selas Fluid Processing Corp.

Blue Bell, PA, U.S.A.
Phone +1.610.834-0300
Fax +1.610.834-0473
john.mcdermott@selasfluid.com

Linde Engenharia do Brasil Ltda.

Rio de Janeiro, Brazil
Phone +55.21.3545-2255
Fax +55.21.3545-2257
jaime.basurto@linde.com

Linde Process Plants (Pty.) Ltd.

Johannesburg, South Africa
Phone +27.11.490-0513
Fax +27.11.490-0412
lindepp@global.co.za

Linde-KCA Russia Branch

Moscow, Russia
Phone +7.495.646-5242
Fax +7.795.646-5243
dirk.westphal@linde-kca.com

Linde Arabian Contracting Co. Ltd.

Riyadh, Kingdom of Saudi Arabia
Phone +966.1.419-1193
Fax +966.1.419-1384
linde-ksa@linde-le.com

Linde Engineering Middle East LLC

Abu Dhabi, United Arab Emirates
Phone +971.2.4477-631
Fax +971.2.4475-953
linde@emirates.net.ae

Linde Engineering India Pvt. Ltd.

Vadodara, Gujarat, India
Phone +91.265.3056-789
Fax +91.265.2335-213
sales@linde-le.com

Linde Engineering Far East, Ltd.

Seoul, South Korea
Phone +82.2789-6697
Fax +82.2789-6698
hanyong.lee@linde.com

Linde Engineering Division

Bangkok, Thailand
Phone +66.2636-1998
Fax +66.2636-1999
anuwat.krongkrachang@linde.com

Linde Engineering Co. Ltd.

Dalian, P.R. of China
Phone +86.411.39538-800
Fax +86.411.39538-855
jochen.nippel@lindeleh.com

Linde Engineering Co. Ltd.

Hangzhou, P.R. of China
Phone +86.571.87858-222
Fax +86.571.87858-200
hangzhou.leh@lindeleh.com

Linde Engineering Division

Beijing Representative Office
Beijing, P.R. of China
Phone +86.10.6437-7014
Fax +86.10.6437-6718
linde@public.bta.net.cn

Linde AG Taiwan Branch

Engineering Division
Taipei, Taiwan
Phone +886.2.2786-3131
Fax +886.2.2652-5871
bernhard.puerzer@linde-le.com

Linde Australia Pty. Ltd.

Chatswood N.S.W., Australia
Phone +61.29411-4111
Fax +61.29411-1470
willy.dietrich@linde.com.au

Linde AG

Engineering Division, Head office, Dr.-Carl-von-Linde-Str. 6-14, 82049 Pullach, Germany
Phone +49.89.7445-0, Fax +49.89.7445-4908, E-Mail: info@linde-le.com, www.linde.com