

THE LINDE GROUP

Linde

Plants for a cleaner tomorrow.

Carbon Capture and Storage (CCS).



A promising way to reduce CO₂ emissions. Carbon Capture and Storage (CCS).

When we generate energy, how can we capture the carbon dioxide released in order to prevent this harmful gas from escaping into the atmosphere? And, once captured, where should we store it? With its significant know-how in CO₂ handling, treatment, liquefaction, transport, storage and application, Linde Engineering Dresden answers these questions by working closely with energy providers in order to develop technical solutions for environmentally friendlier electricity and fuels. Our state-of-the-art CO₂ capture technology can also be used in the steel and chemical industries as well as for Enhanced Oil Recovery (EOR) and Enhanced Gas Recovery (EGR).

Count on our expertise

As an internationally recognised company in the design and construction of gas plants, Linde Engineering Dresden has long established expertise in the treatment of CO₂, including its:

- Separation
- Purification
- Compression
- Liquefaction
- Storage in tanks

With this extensive expertise, we can help you realise complete CCS projects according to your special requirements. We offer the full range of engineering services (in respect of CO₂ as well as other gases and chemicals), including:

- Consulting services
- Project development
- Economical and technical feasibility studies
- Support and documentation for authority engineering
- Engineering and design
- Procurement
- Construction
- Commissioning and start-up
- Training of operational and maintenance personnel
- Project management
- Licensing arrangements
- Financing
- After-sales support
- Global sourcing

Carbon capture processes

There are three principal methods of removing carbon dioxide (e.g. from flue gas from fossil-fuelled power generation). Once carbon dioxide is captured, it is further processed: compression, drying and purification are necessary steps before the gas can be stored.

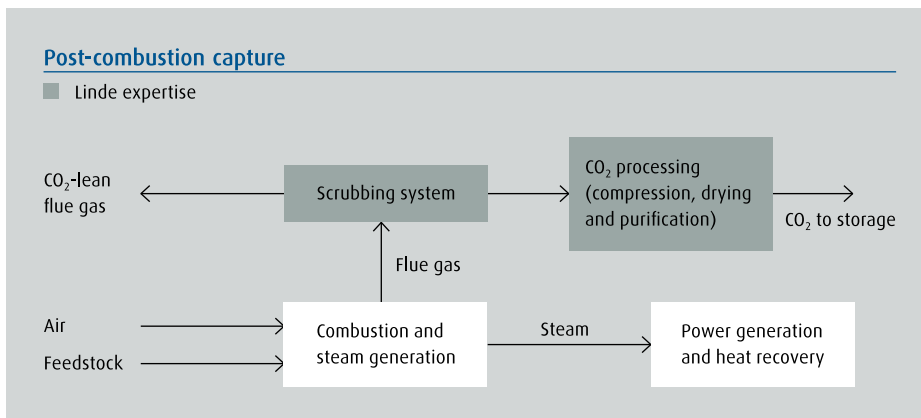

In Post-Combustion Capture (PCC), CO₂ is separated from the flue gas by scrubbing, using a chemical solvent such as amine.

For this process, Linde provides the amine-based solvent systems and the CO₂ compression, drying and purification system.

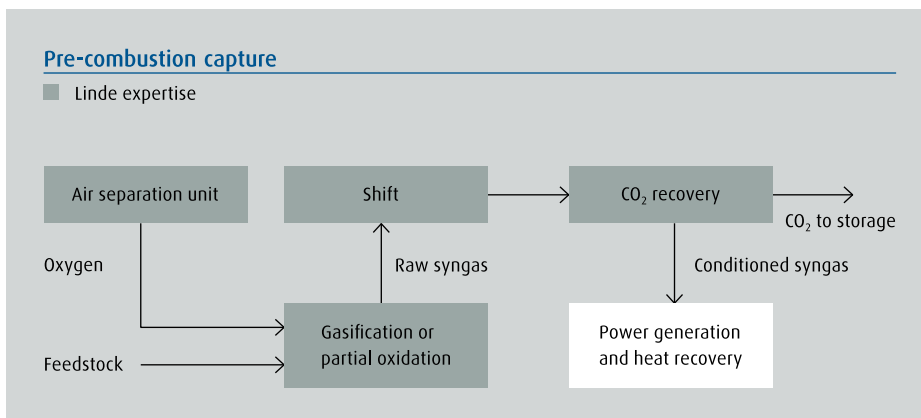

In pre-combustion capture, also known as IGCC (Integrated Gasification Combined Cycle), the fuel is first gasified with oxygen to produce a synthesis gas. This gas is then chemically converted into separate streams of carbon dioxide and hydrogen in the so-called shift reaction ($\text{CO} + \text{H}_2\text{O} \rightleftharpoons \text{CO}_2 + \text{H}_2$).

For this process, Linde provides the air separation unit for the production of oxygen, the gasification system as well as the synthesis gas separation and purification systems including shift and RECTISOL® selective CO₂ recovery.

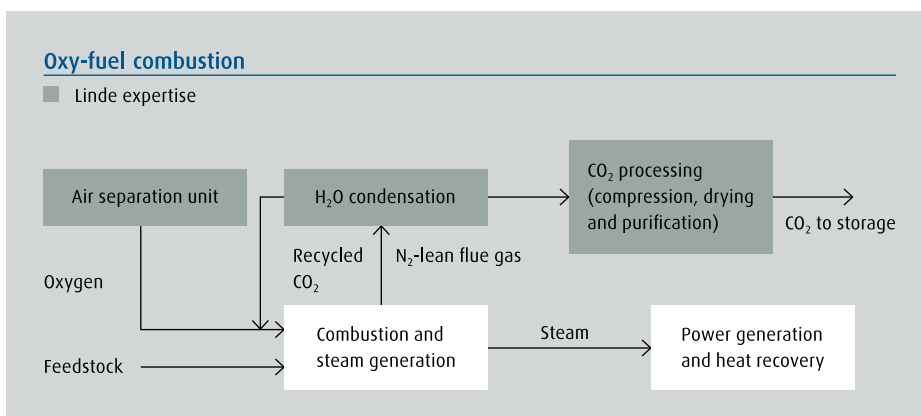

In oxy-fuel combustion, the fuel is combusted with oxygen and recycled CO₂-rich flue gas. Oxygen is used instead of air to reduce the nitrogen concentration in the flue gas. This allows for the cost-effective recovery of CO₂ from the flue gas.

For this process, Linde provides the air separation unit for the production of oxygen, the CO₂ compression, drying and purification system as well as an optional liquefaction system.

Easy integration with existing plants. Post-Combustion Capture (PCC).

For post-combustion capture, a solvent (e. g. amine) is needed to absorb the CO_2 from the flue gas. This process step takes place in the absorption column. In the desorption column, the CO_2 is removed from the rich solvent at increased temperatures. The lean solvent is then recirculated to the absorption column. After passing through the absorption column, the flue gas is almost completely freed of its CO_2 impurities (about 90% reduction) and can be released into the atmosphere.

The great advantage of PCC is that it has no effect on the power plant process itself as it is applied downstream. It can thus be installed retroactively, e. g. during refurbishment of existing plants.

Linde has long experience in the washing of gases. Our systems for amine washing, for example, are used in a wide range of applications in the chemical industry. Furthermore, we offer our own proprietary RECTISOL®Wash process, using methanol for the selective removal of $\text{H}_2\text{S}/\text{COS}$ and CO_2 from gasification-process synthesis gas for pre-combustion technology.

Process overview (pilot plant in Niederaussem)

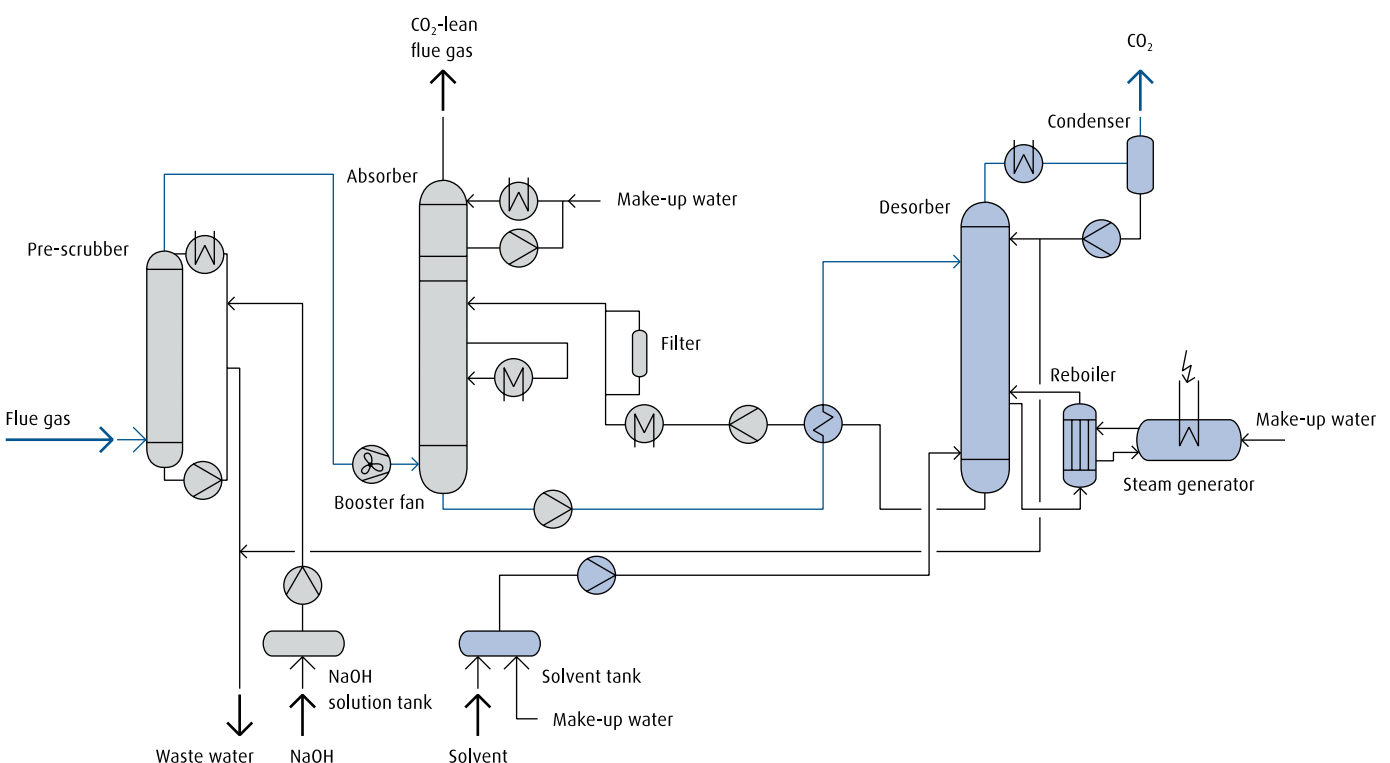



Pilot plant for post-combustion capture in Niederaussem

Reference: PCC pilot plant in Niederaussem, Germany

In Niederaussem, Linde Engineering Dresden has installed a PCC pilot plant, which is connected to the world's most modern lignite-fired power plant. It will be integrated into the flue gas circuit of the power plant, dealing with a fraction of the actual flue gas stream.

The project is the result of a cooperation between Linde, the power plant operator RWE, and BASF, which is developing a new CO₂ solvent. The consortium's aim is to investigate how the CO₂ stream can be separated more effectively – particularly in terms of energy efficiency. Another valuable opportunity is the ability to test different construction materials in order to find out which ones possess the required properties (resistance, durability etc.) and are able to fulfil the necessary functions in the most cost-efficient way. In addition, Linde Engineering Dresden has developed a concept for a large-scale CO₂ plant for commercial applications.

Linde Engineering Dresden is responsible for the detailed engineering, equipment procurement and construction of the pilot plant. The plant was commissioned in 2009 and is in operation for testing from 2010 to 2013.

Pure oxygen for perfect results. Oxy-fuel combustion.

In the oxy-fuel combustion process, the fuel is combusted in an atmosphere of oxygen, steam and carbon dioxide. By using pure oxygen instead of air, the nitrogen concentration in the flue gas (about 78 % in normal air) is significantly reduced to about 14 %. The flue gas stream is therefore smaller and easier to handle. After the removal of dust and sulphur from the flue gas, the residual water vapour entrained with the fuel is condensed, leaving the flue gas with much higher levels of carbon dioxide concentration (approximately 80 %). Water vapour and impurities are removed by cooling and compressing the gas stream, leaving a liquefied CO₂ stream with a purity of more than 99 %. In addition, the risk of thermal NO_x formation is reduced since a fuel's inherent nitrogen content is a major source of NO_x. The oxygen needed for oxy-fuel combustion is supplied from air separation plants, whose design and construction has been one of our specialties ever since Dr. Carl von Linde invented air liquefaction and separation in 1895. For oxy-fuel combustion, we also provide the required CO₂ liquefaction plants.

Process overview (pilot plant in Schwarze Pumpe)

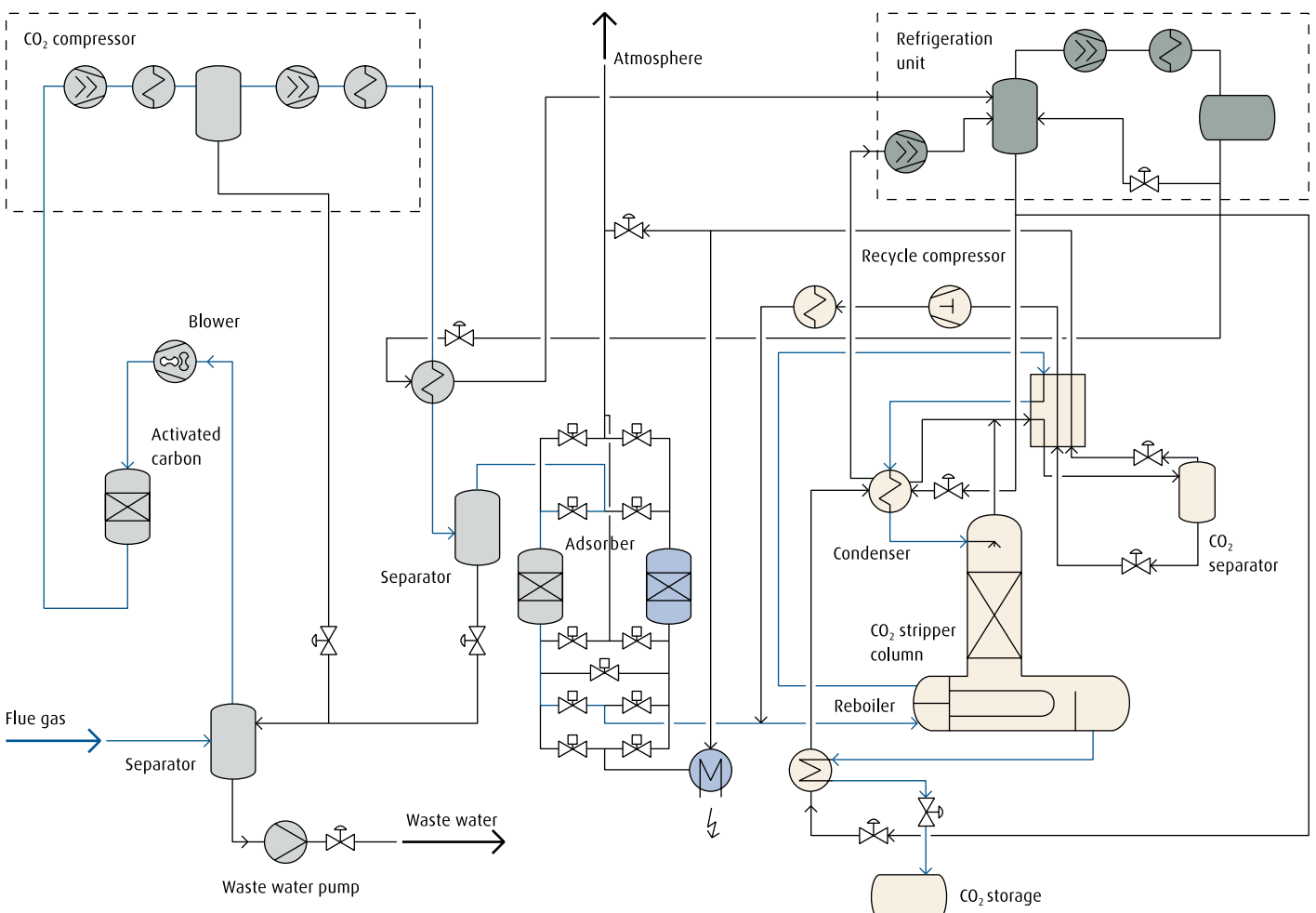

Reference: Oxy-fuel pilot plant in Schwarze Pumpe, Germany

In 2008, Vattenfall officially opened the world's first oxy-fuel pilot plant, a 30-MW_{th} coal-fired power station with CO₂ capture technology, in Schwarze Pumpe. Based on a turnkey lump sum contract, Linde Engineering Dresden constructed both key plants of this project, an air separation unit and a CO₂ liquefaction plant.

Linde has also entered into a technology partnership with Vattenfall, providing extensive scientific and technical expertise during the test phase which will last until the end of 2011. The aim of this collaboration is to test the oxy-fuel combustion process for lignite and anthracite and to advance the technology for subsequent use in larger power stations. Moreover, Linde has made a study for Vattenfall for a 250-MW_{el} oxy-fuel demonstration plant and a 125-MW_{el} post-combustion capture demonstration plant in Jämschwalde, Germany.

Oxy-fuel pilot plant in Schwarze Pumpe



Exploring new ground.

Carbon storage (sequestration).

Using the processes described to separate CO₂ is an important step along the route to green energy generation. However, a mature solution for the disposal of this gas is not yet available. One method currently on trial is sequestration, i.e. CO₂ storage below the ground or seabed. However, the CO₂ sequestration step is still in its development stages.

In order to take CCS to the next level, Linde Engineering Dresden is fully committed to the advancement of carbon storage technologies and takes part in pioneering pilot projects.

Main methods of CO₂ storage are:

- Storage in caverns
- Storage in depleted oil and gas fields
- Storage in saline aquifers

The sites for CO₂ storage have to be intensively investigated by a detailed analysis of the geological properties of the containing layers, with particular consideration to impermeability, seismic activity, capacity etc.

Reference: CO₂ injection plant in Maxdorf, Germany

In 2009, Linde Engineering Dresden commissioned a CO₂ injection plant in Maxdorf. In this pilot project, the CO₂ from the oxy-fuel plant at Schwarze Pumpe will be injected into a gas field.

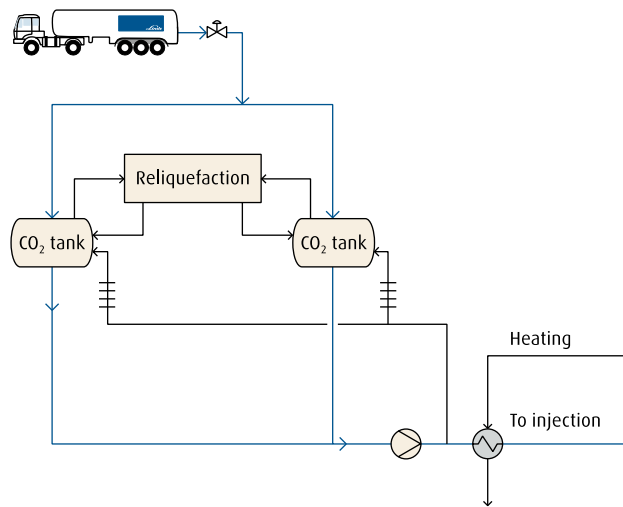

CO₂ injection plant in Maxdorf (pilot plant)



A two-in-one solution. Enhanced oil/gas recovery as a form of carbon storage.



EOR plant in Cantarell

As the world's oil and gas reserves are on the decline, more and more development efforts are directed towards the enhancement of extraction yields. One technique of Enhanced Oil Recovery (EOR) and Enhanced Gas Recovery (EGR) is to inject gas (e.g. N_2 or CO_2) into the deposit. The pressure inside the deposit rises and the fuel's characteristics change (in EOR, the oil's viscosity is reduced). This results in better flow rates and increased extraction.

Depending on the pressure, part of the injected gas is brought back to the surface (dissolved or mixed with the oil stream) and is then reinjected. A certain fraction of the injected gas, however, remains under ground. EOR/EGR with carbon dioxide therefore accomplishes two goals at once: extraction yields are enhanced and CO_2 emissions are reduced.

Nitrogen obtained by cryogenic air separation is the driving gas in the majority of existing EOR facilities (see reference below). When considering power plants that employ CCS, several possibilities for EOR/EGR emerge: obsolete nitrogen from air separation as well as captured CO_2 from PCC or IGCC can be used as injection gases.

Reference: Enhanced Oil Recovery (EOR) plant in Cantarell, Mexico

In 2000, Linde constructed the world's largest multi-train air separation plant in Cantarell. This is connected to the world's biggest offshore oil field, situated in the Gulf of Mexico at the Campeche Bay. The plant generates nitrogen which is used to increase the rate of yield from the oil field. In this example, nitrogen is the driving gas. Carbon dioxide, however, would provide an additional opportunity for increasing the extraction yields.

References for CCS projects since 2006

Customer, location, country	Plant type	Scope of work	Capacity	Purity	Year of order
Maasvlakte CCS Project C.V. , Rotterdam, Netherlands	Post-combustion capture, CO ₂ flue gas wash unit (demonstration plant)	FEED study	4 100 t/d CO ₂	> 99.0 % CO ₂	2010
RWE Power AG , Essen, Germany	CO ₂ purification and liquefaction plant	Feasibility study	8 600 t/d CO ₂ liquid	> 99.5 % CO ₂	2009
Vapo Oy , Finland	CO ₂ purification and liquefaction plant	Feasibility study	1 920 t/d CO ₂ liquid	> 98.0 % CO ₂	2009
Linde Process Plants for Faustina Hydrogen Products , LA, USA	CO ₂ purification and compression	FEED study	349 000 Nm ³ /h feedgas	> 99.0 % CO ₂	2008
Vattenfall , Jänschwalde, Germany	Post-combustion capture, CO ₂ flue gas wash unit and compression	Feasibility study	3 000 t/d CO ₂	> 99.0 % CO ₂	2008
RWE Power AG , Niederaussem, Germany	Oxy-fuel technology Post-combustion capture, CO ₂ flue gas wash unit (pilot plant)	Feasibility study Project management, basic engineering, detail engineering, equipment supply, erection, start-up, test run	5 650 t/d CO ₂ 7.2 t/d CO ₂	> 96.5 % CO ₂ > 99.0 % CO ₂	2008
StatoilHydro , Hammerfest, Melkoya Island, Norway	Post-combustion capture, CO ₂ flue gas wash unit and compression	Feasibility study	3 465 t/d CO ₂	> 99.0 % CO ₂	2008
GFZ Potsdam , Ketzin, Germany	CO ₂ storage and injection	Turnkey plant	20 t/d CO ₂	> 99.0 % CO ₂	2007
PEG (Gaz de France) , Maxdorf, Germany	CO ₂ injection (pilot plant for EGR)	Turnkey plant	770 t/d CO ₂	> 99.7 % CO ₂	2007
Vattenfall , Schwarze Pumpe, Germany	Oxy-fuel technology, CO ₂ purification and liquefaction plant (pilot plant)	Turnkey plant	240 t/d CO ₂ liquid	> 99.7 % CO ₂	2006

Planting seeds for the future.

Our customers' success is our success. With innovative technologies and our employees' extensive know-how, we are consistently turning our customers' goals into our own – in a fair, transparent and cost-conscious manner. Therefore, every plant we build is a reference for the next one – creative in its concept, efficient in its implementation.

As one of the leading companies in the planning and construction of plants, we offer our customers the security of consistently high quality standards. In cooperation with reliable business partners, we combine capacity and expertise in order to realise projects of any dimension.

We regard every assignment as a chance to define a new market standard and to expand our strong international position. Driven by our own performance capability, it is our goal to make the name Linde a globally recognised seal of quality, with plants that speak for themselves – and for us.

Linde AG, Engineering Division

Head office
Pullach, Germany
Phone +49.89.7445-0
Fax +49.89.7445-4908
info@linde-le.com

Selas Fluid Processing Corp.

Blue Bell, PA, U.S.A.
Phone +1.610.834-0300
Fax +1.610.834-0473
john.mcdermott@selasfluid.com

Linde Engineering Middle East LLC

Abu Dhabi, United Arab Emirates
Phone +971.2.4477-631
Fax +971.2.4475-953
linde@emirates.net.ae

Linde Engineering India Pvt. Ltd.

Vadodara, Gujarat, India
Phone +91.265.3056-789
Fax +91.265.2335-213
sales@linde-le.com

Linde Engineering Dresden GmbH

Bodenbacher Strasse 80, 01277 Dresden, Germany
Phone +49.351.250-30, Fax +49.351.250-4800, www.linde-engineering.com